

9.0.1 Hatz Engine CM1650

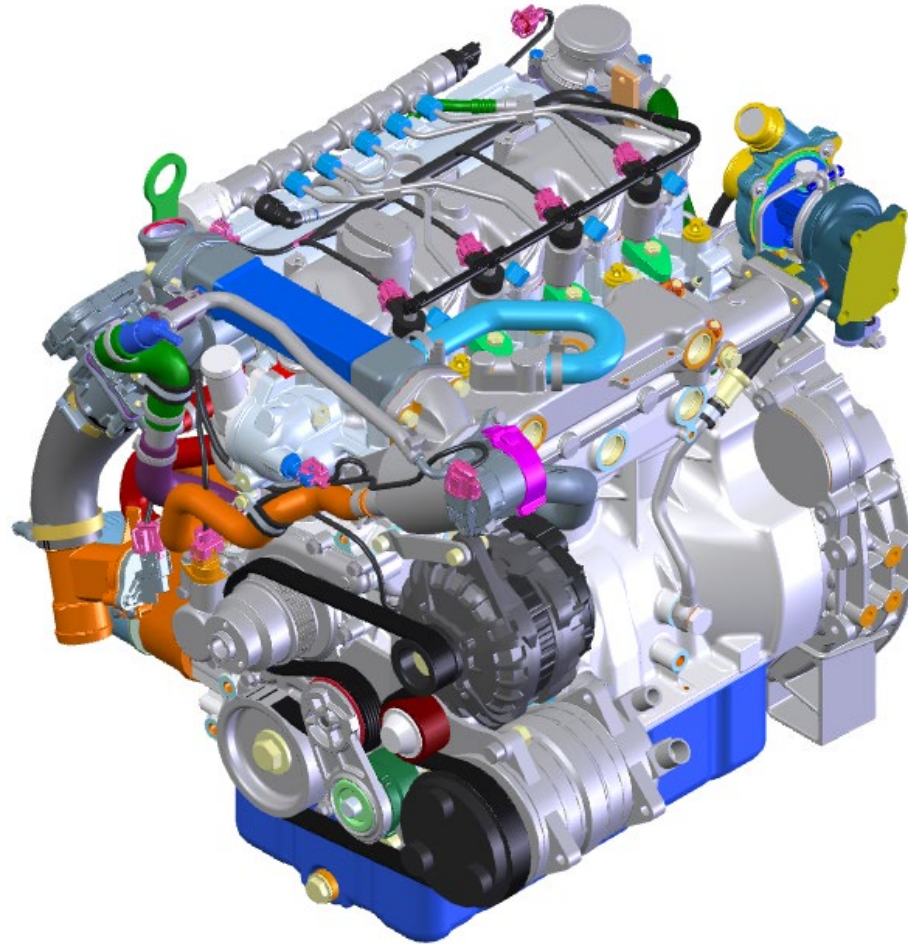

Note: This document is used to provide an overview of the system. For diagnosis and repair work on the Hatz engine, it is absolutely necessary that the Hatz Diagnostics software, error message list and the workshop manual are available.



Contents

Technical Data	3 - 4
Type plate	5
Display indications (DPF)	6
Overview of engine parts	7 - 21
Fuel - High Pressure System	22 - 26
Engine electrics	27 - 29
DPF regeneration	30 - 37

Technical data

Type of construction	Liquid-cooled 4-cylinder four-stroke diesel engine
Injection system	Bosch Off-Highway Common Rail
Charging system	Turbo with charge air cooling
Exhaust gas post-treatment	gAGR, DOC, DPF
Bore x stroke (mm)	84 x 88
Displacement (ccm)	1952
Compression ratio	17,5 : 1
Power (KW)	54,9
Idle speed (rpm)	1100
Full load speed (rpm)	2600
Lubricating oil filling (l)	7,2L
Max. Oil consumption	0.5% of fuel consumption at full load
Engine oil pressure (bar))	2,5 to 4,5
Max. Injection pressure (bar)	1800
Direction of rotation	Left (view on flywheel)
Valve clearance	Automatic compensation (maintenance-free)
Engine oil quality	Fuchs Titan CARGO 5W-40, Spezifikation ACEA E9, API CK-4
Coolant	G13 or comparable, e.g. Total Glacelf Auto Supra.
Fuel	EN590, BS2689A1/A2, ASTM D 975-09a 1-D S15 oder 2-D S15, JIS K2204

Technical data

Characteristics

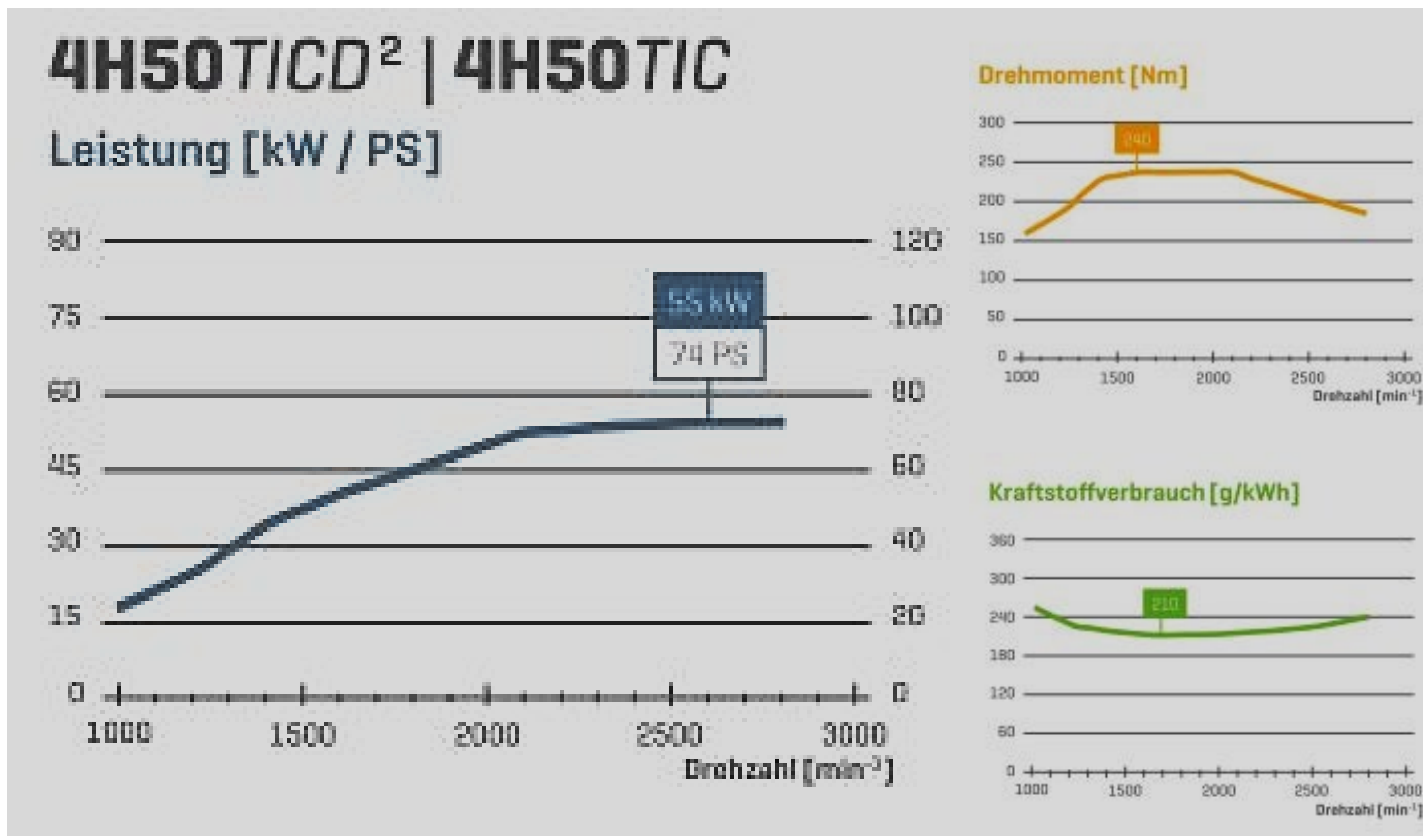

Technical data

Type plate

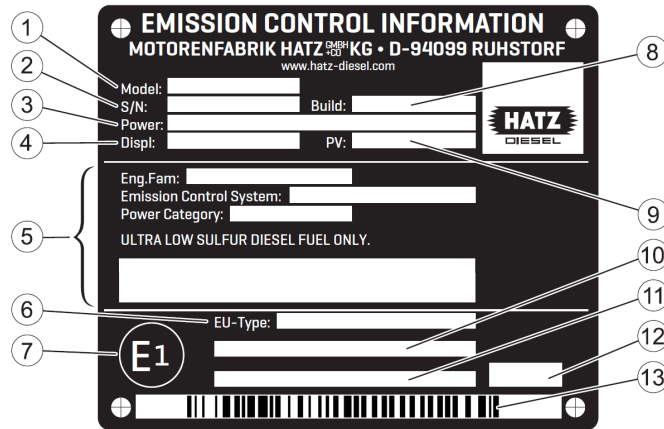

Structure of the serial number

AAA BB CC DDDDDD

- AAA = Motortype = 165
- BB = Series = 10 (und größer)
- CC = year of construction
- DDDDDD = counting Nummer

example 165 10 19 000065

The motor type plate is attached to the crankcase and contains the following motor data:

1. Engine model designation
2. Engine number
3. Engine power (kW) at rated speed (RPM)
4. Hubraum (Liter)
5. Information for US emission certification (EPA/CARB)
6. EU type approval number
7. EU country of origin (Germany)
8. Year of manufacture (month/year)
9. Test specification for special settings
10. Engine family designation or exception code (EM) or transition code (TM) according to Regulation (EU) 2016/1628.
11. Additional information according to regulation 2017/656 (exemptions) or "Separate shipment information".
12. Code for nameplate variant
13. Barcode (Engine number)

Display indication

DPF



Error message as SPN / FMI code
SPN 3-6-digit / FMI 1-2-digit
Error message s. Chapter 9.0.6



Engine or drive fault



Error in the DPF



(flashing) engine fault



DPF regeneration required



Limb Home Modus activated



Regeneration locked

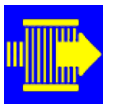

Warning air filter clogged



Active regeneration is running

Overview Engine Parts

Intake air

Sensor Differenzdruck Luftfilter B31
(Wartungsanzeige Luftfilter)
Sensor Differential Pressure Air Filter
(Maintenance indicator air filter)
PN 01503300

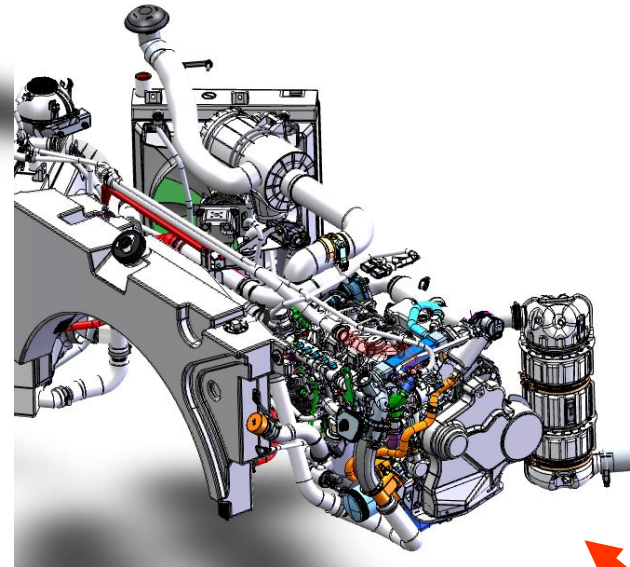
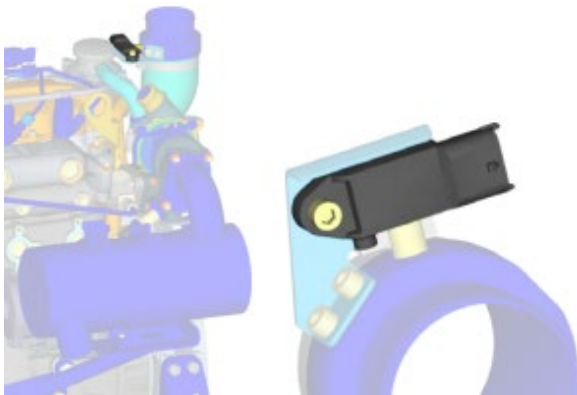
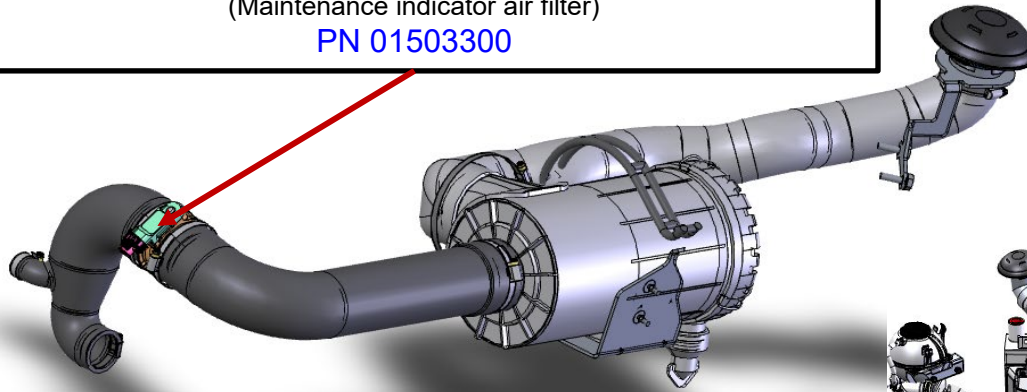

Fahrtrichtung - Driving Direction

Overview Engine Parts

Right view of the Engine

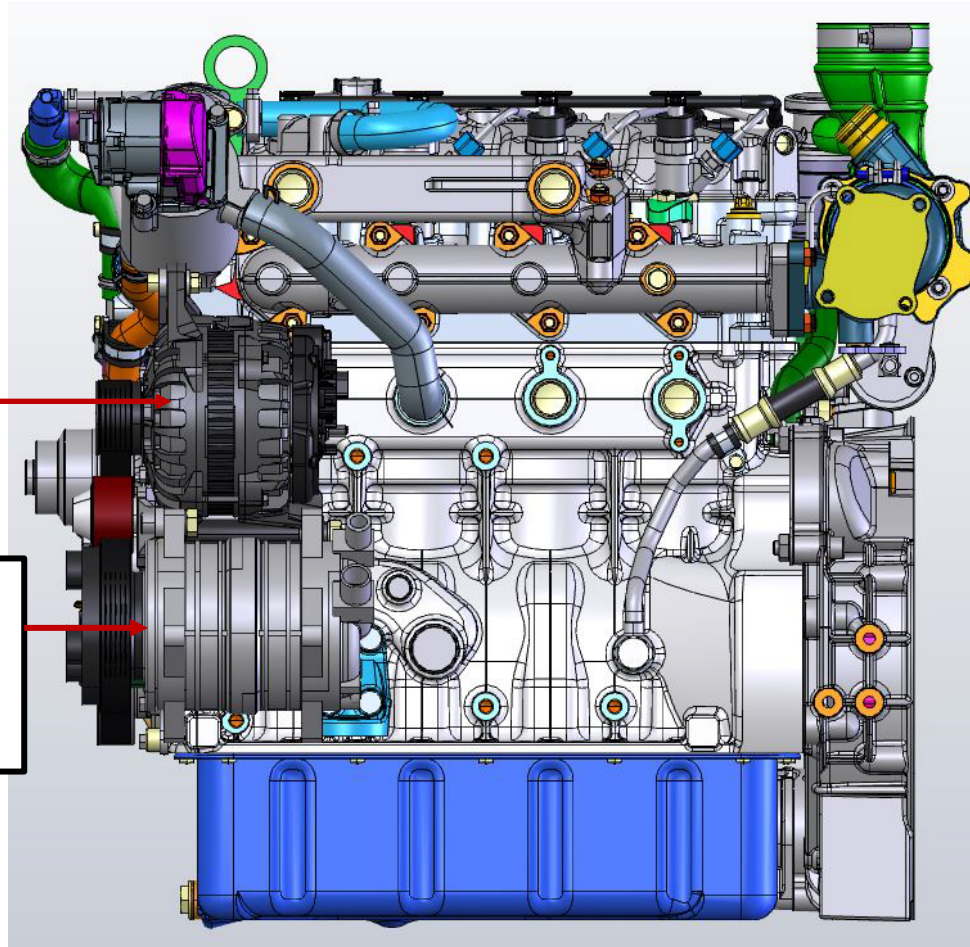

Generator G2
PN 01503380

Klimakompressor mit
Kupplung Y09
A/C compressor with clutch
Y09
PN 01503450

Overview Engine Parts

Left view of the Engine

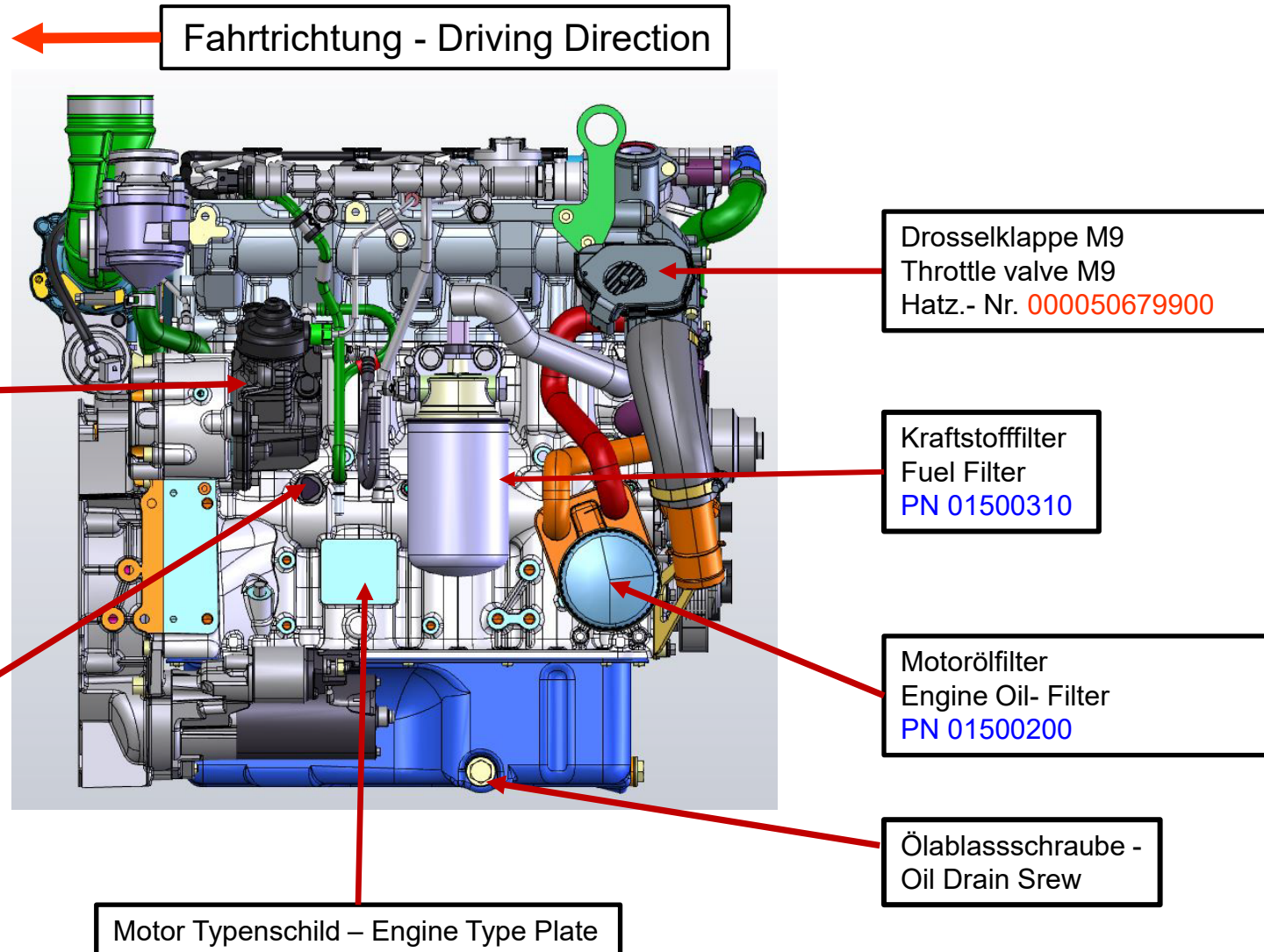

Overview Engine Parts

Left view of the Engine

Kurbelwellen-
Drehzahlsensor B5
Crankshaft Sensor B5

Öldruck- und
Temperatursensor B9
Oil pressure and
temperature sensor B9

Kraftstoff Niederdruck- und
Temperatursensor B3
Fuel low pressure and
temperature sensor B3

PFM- Sensor B32
(Luftmassenmesser)
PFM- Sensor B32
(Air Rate Meter)
PN 01503580

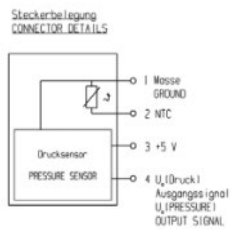
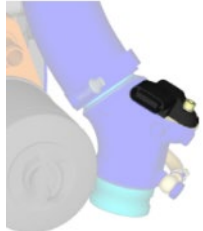
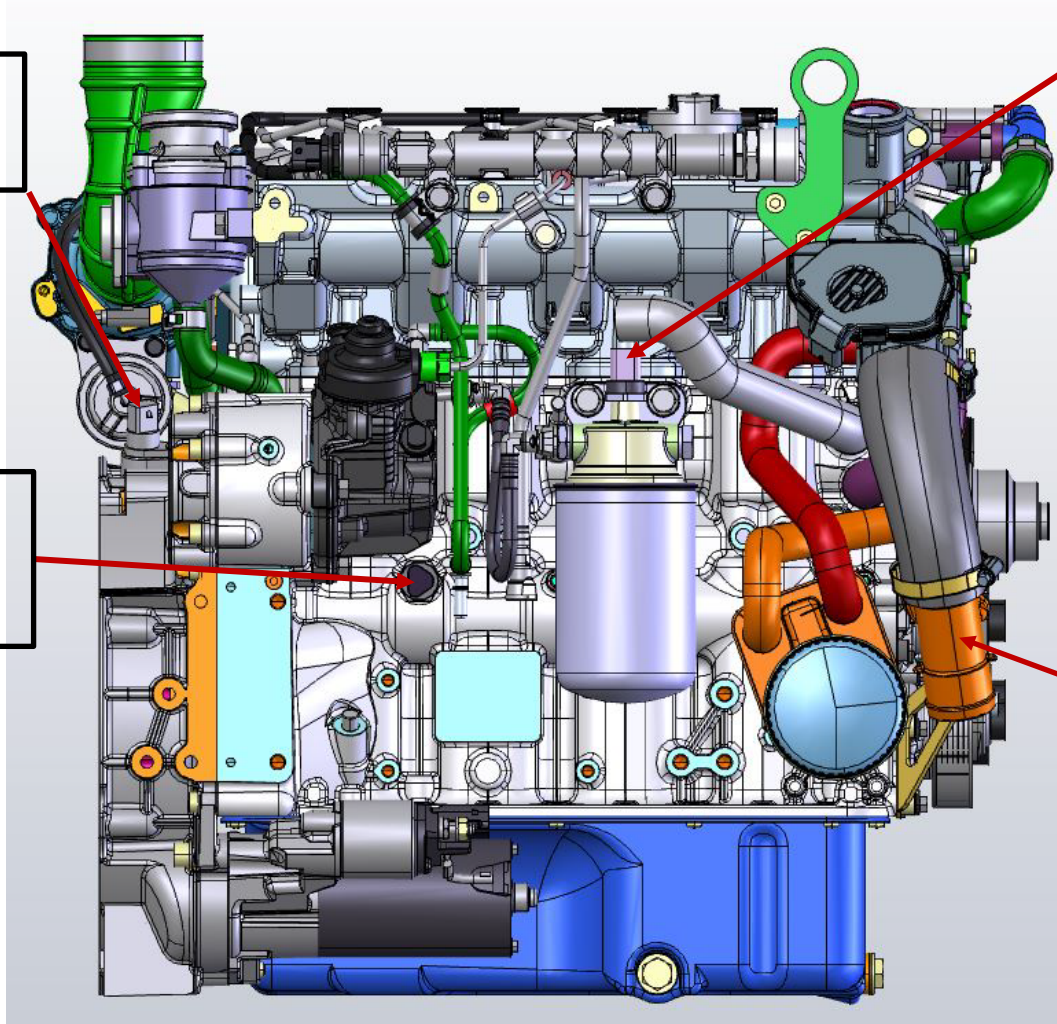

← Fahrtrichtung - Driving Direction

Overview Engine Parts

Top view of the Engine

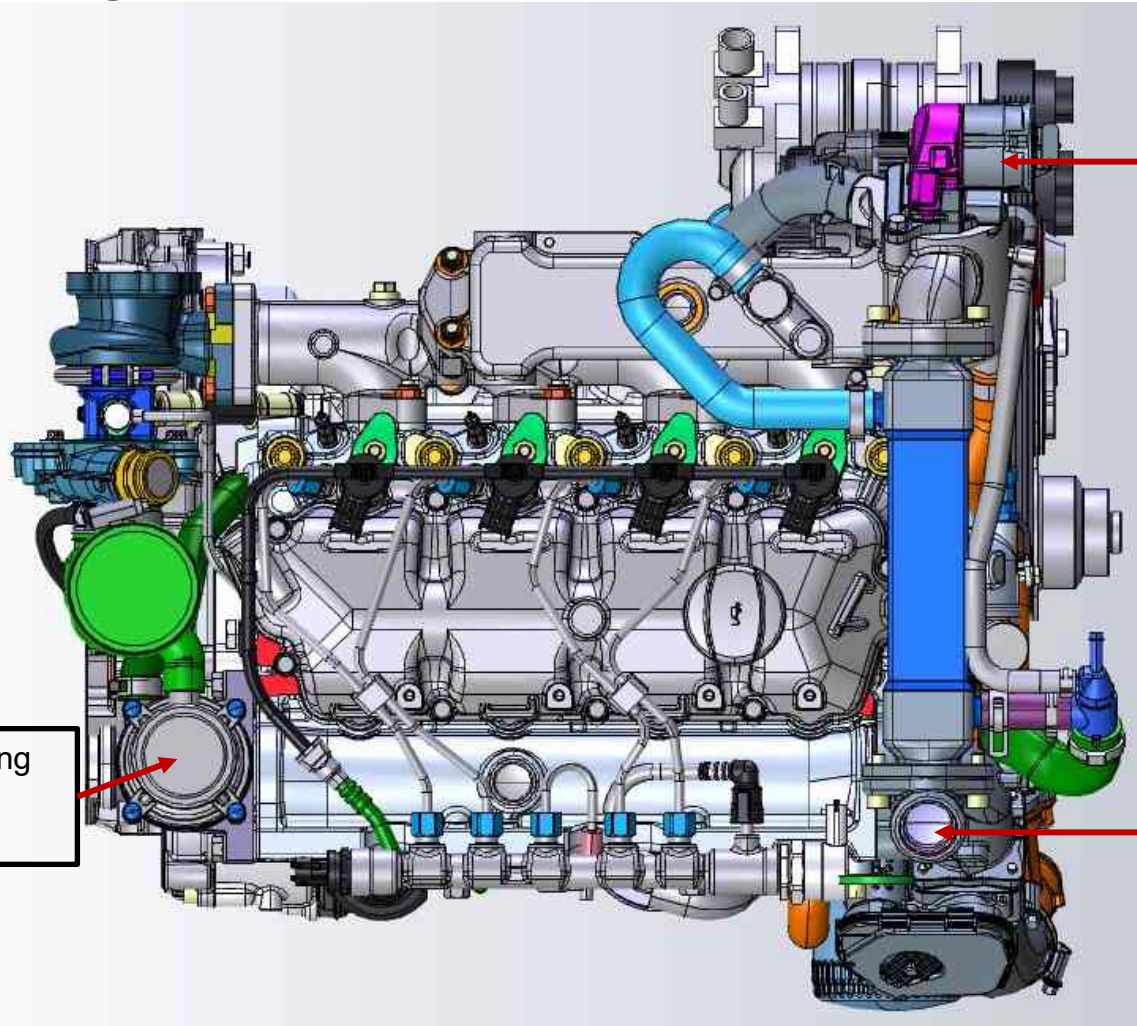

AGR- Ventil M8
(Ventil für
Abgasrückführung)
EGR- Valve M8
(Valve for Exhaust Gas
Recirculation)
PN 01503060

Kurbelgehäuse- Entlüftung
Crankcase Ventilation
PN 01501990

Drosselklappe M9
Throttle Valve M9
Hatz.- Nr.
000050679900

← Fahrtrichtung - Driving Direction

Overview Engine Parts

Bottom view of the Engine

Anlasser M5
Starter- Motor M5
PN 01503720

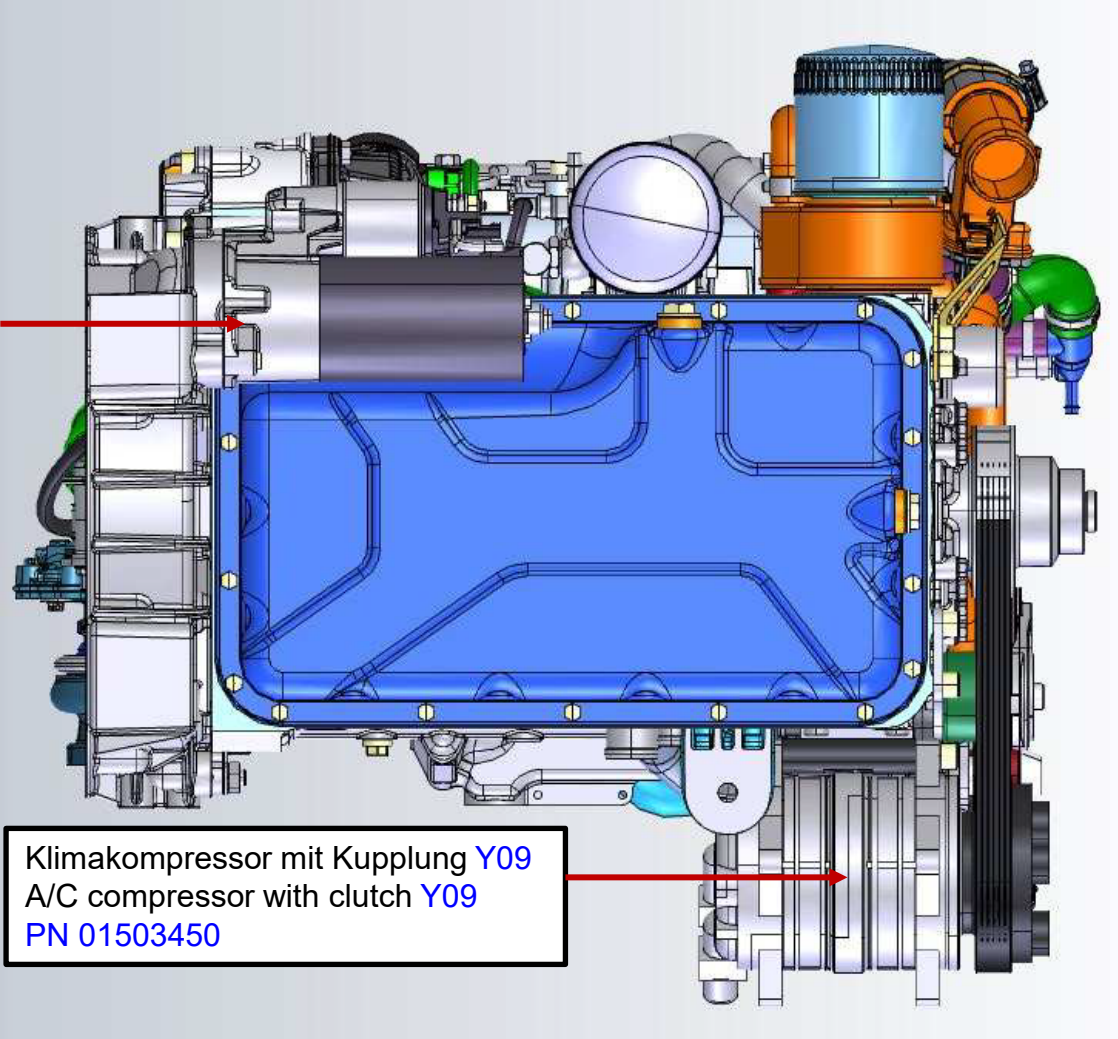

Klimakompressor mit Kupplung Y09
A/C compressor with clutch Y09
PN 01503450

← Fahrtrichtung - Driving Direction

Overview Engine Parts

View on flywheel

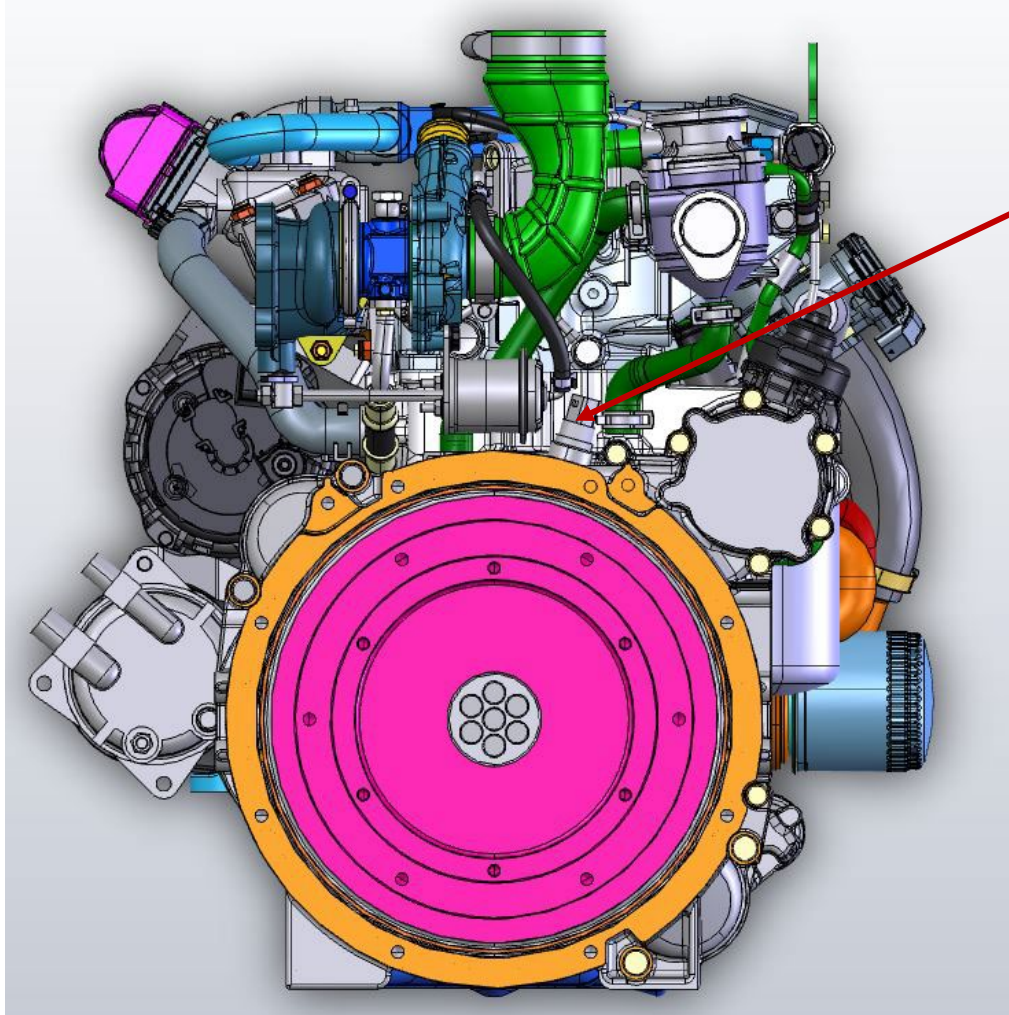

Kurbelwellen – Drehzahlsensor B5
Crankshaft Speed Sensor B5



Overview Engine Parts

Rear view of the Engine

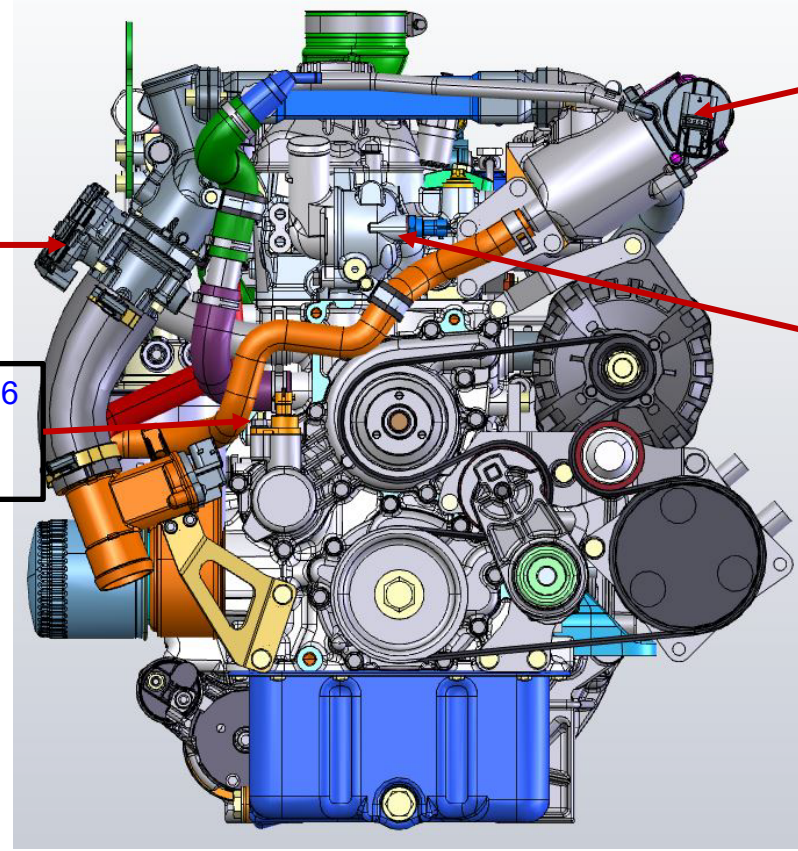

Drosselklappe M9
Throttle Valve M9
Hatz.- Nr. 000050679900

Nockenwellen- Drehzahlsensor B6
Camshaft- Speed Sensor B6
PN 01503590

AGR Ventil M8
EGR Valve M8
PN 01503060

Temperatursensor
Motor- Kühlmittel B4
Temperature- Sensor
Engine Coolant B4
PN 01503780

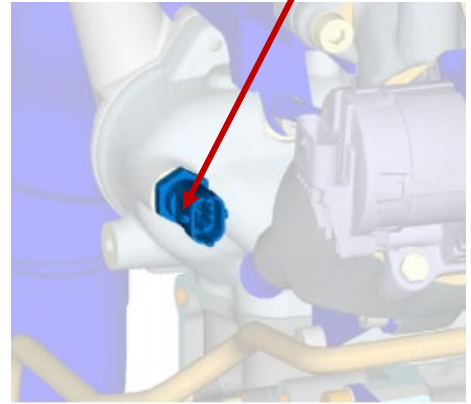
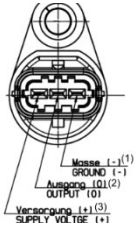
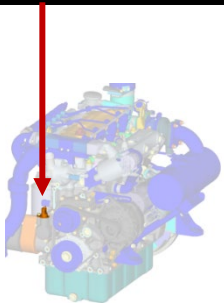

Fahrtrichtung - Driving Direction

Overview Engine Parts

DPF

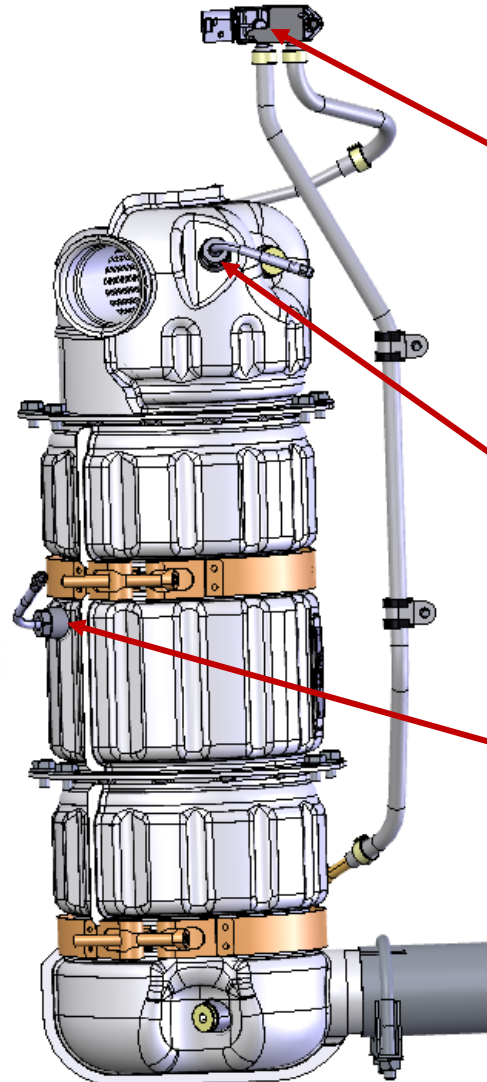
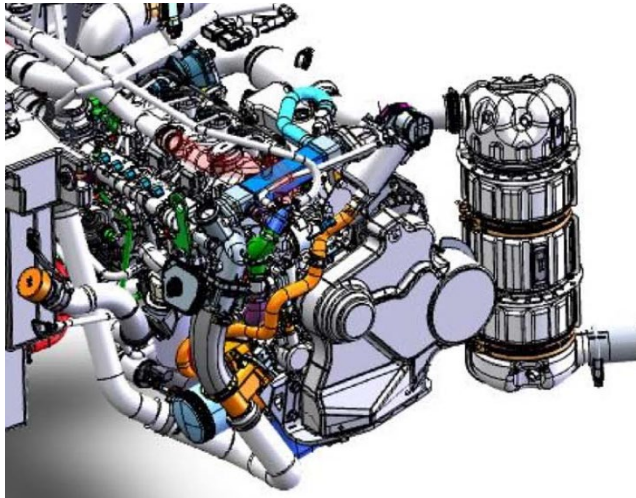

Differenzdruck- Geber DPF B35
Differential – Pressure- Sensor DPF B35
PN 01503300

DPF- Abgassensor T1
(Temperatur vor OXI- Kat B36)

DPF- Exhaust Gas Sensor T1
(temperature before OXI- Cat B36 Upstream)
PN 01503300

DPF- Abgassensor T2
(Temperatur nach OXI- Kat B37)

DPF exhaust gas sensor T1
(temperature after to OXI- Cat B37 Downstream)
PN 01503300

Overview Engine Parts

Fuel low pressure system

Kraftstoffförderpumpe M10
Fuel Pump M10
PN 01503330

Filterpatrone Kraftstoffvorfilter
mit Wasserabscheider
Filter Cartridge Fuel Filter
with Water Separator
PN 01500420

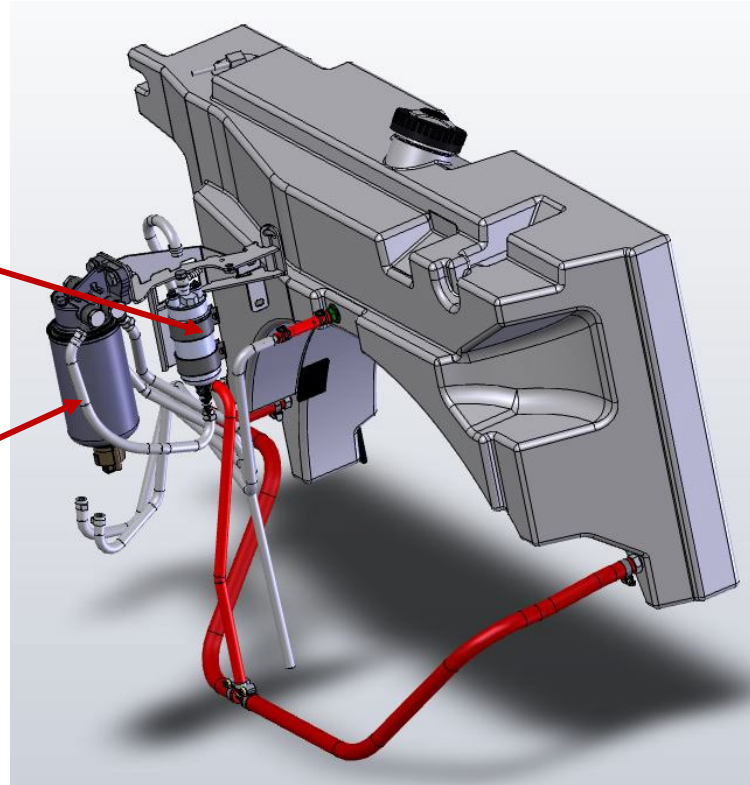

Kraftstoffniederdruck-
und Temperatursensor B3

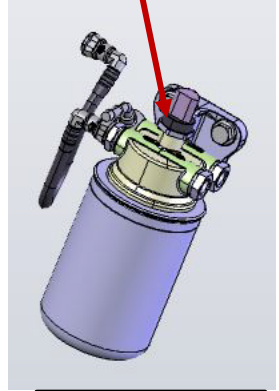

Kraftstofffilter



Sensor Wasser im Kraftstoff B07
Sensor water in the fuel B07
PN 01503360

Overview Engine Parts

Fuel low pressure system

Water in Fuel Sensor (conductivity measurement):

This method is also known as conductive measurement. When reaching a certain level of electrical current between two electrodes by the liquid. This changes the resistance between two measuring electrodes by the presence or absence of the medium.



Water in Fuel Sensor B33

Overview Engine Parts

Turbocharger

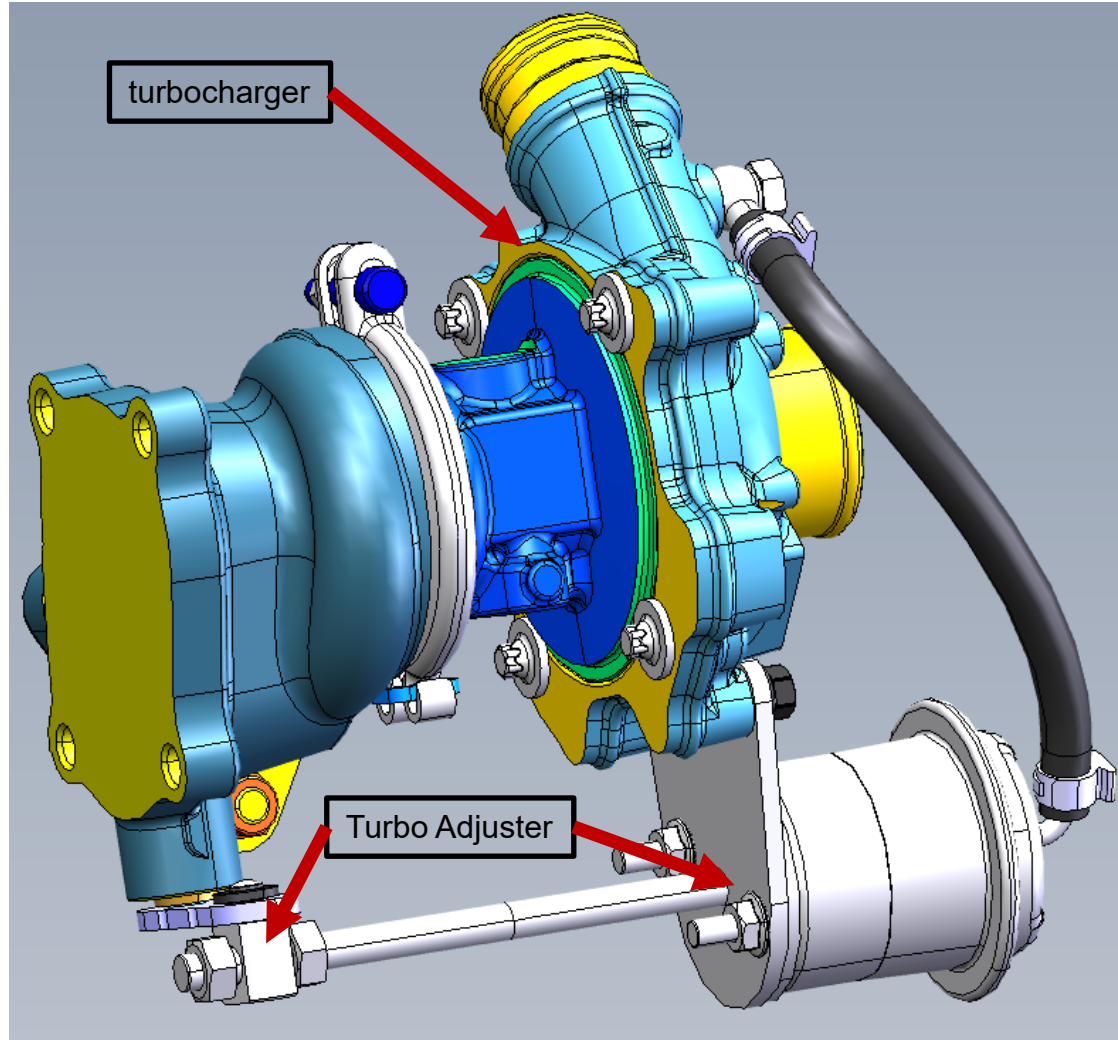

Overview Engine Parts

Fresh air system

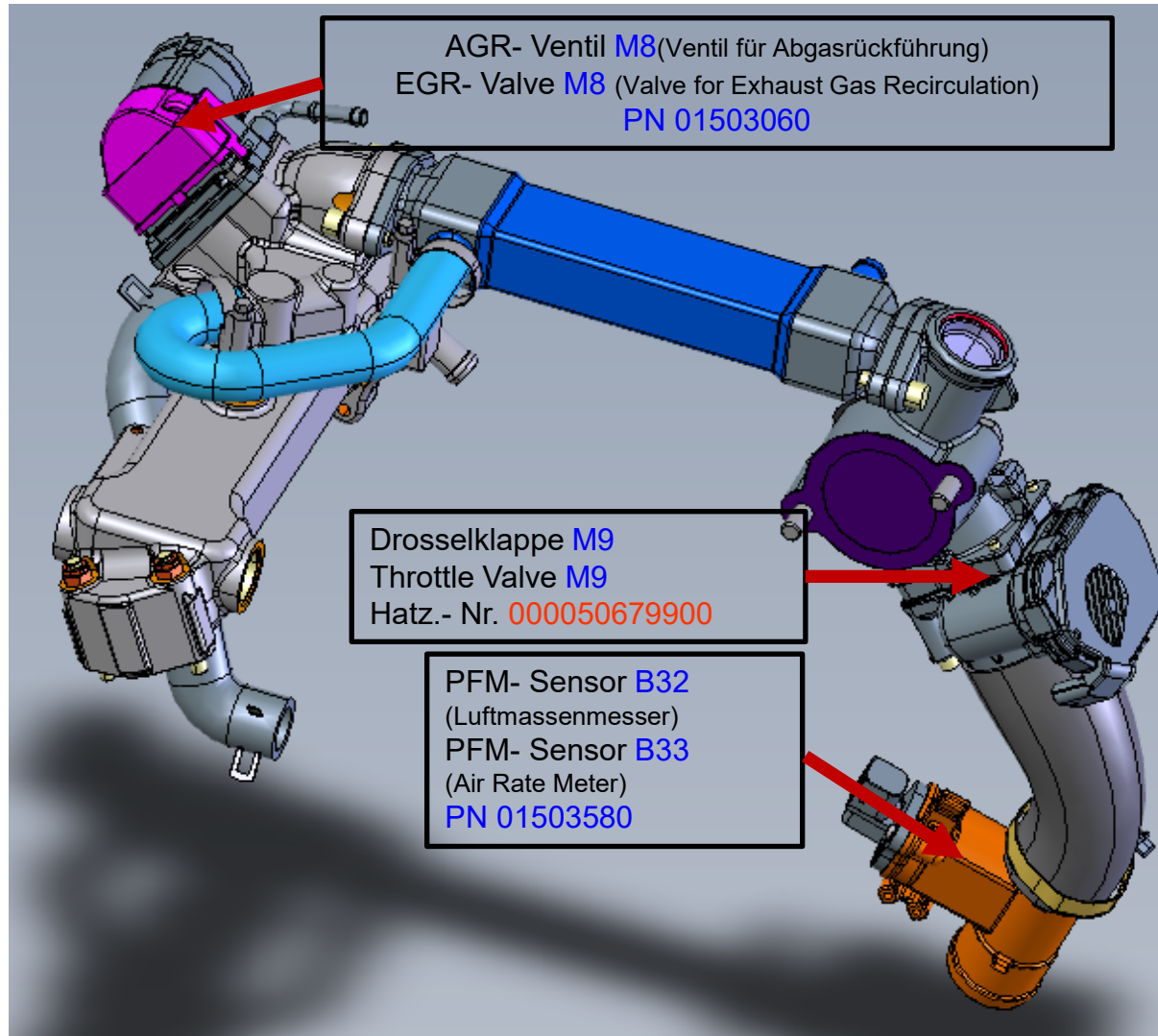

Overview Engine Parts

Cooling system

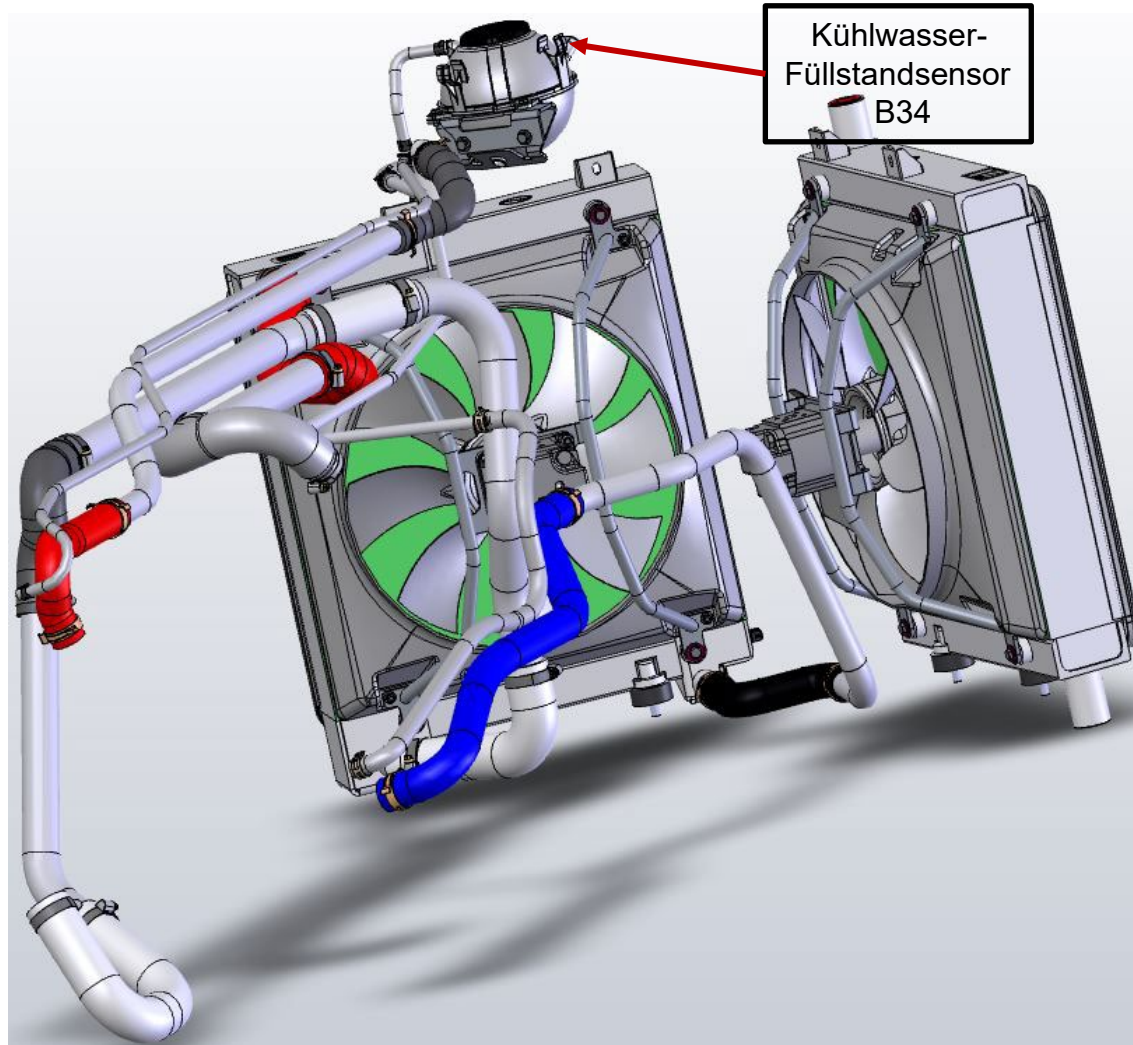

Overview Engine Parts

Generator and air-conditioning compressor

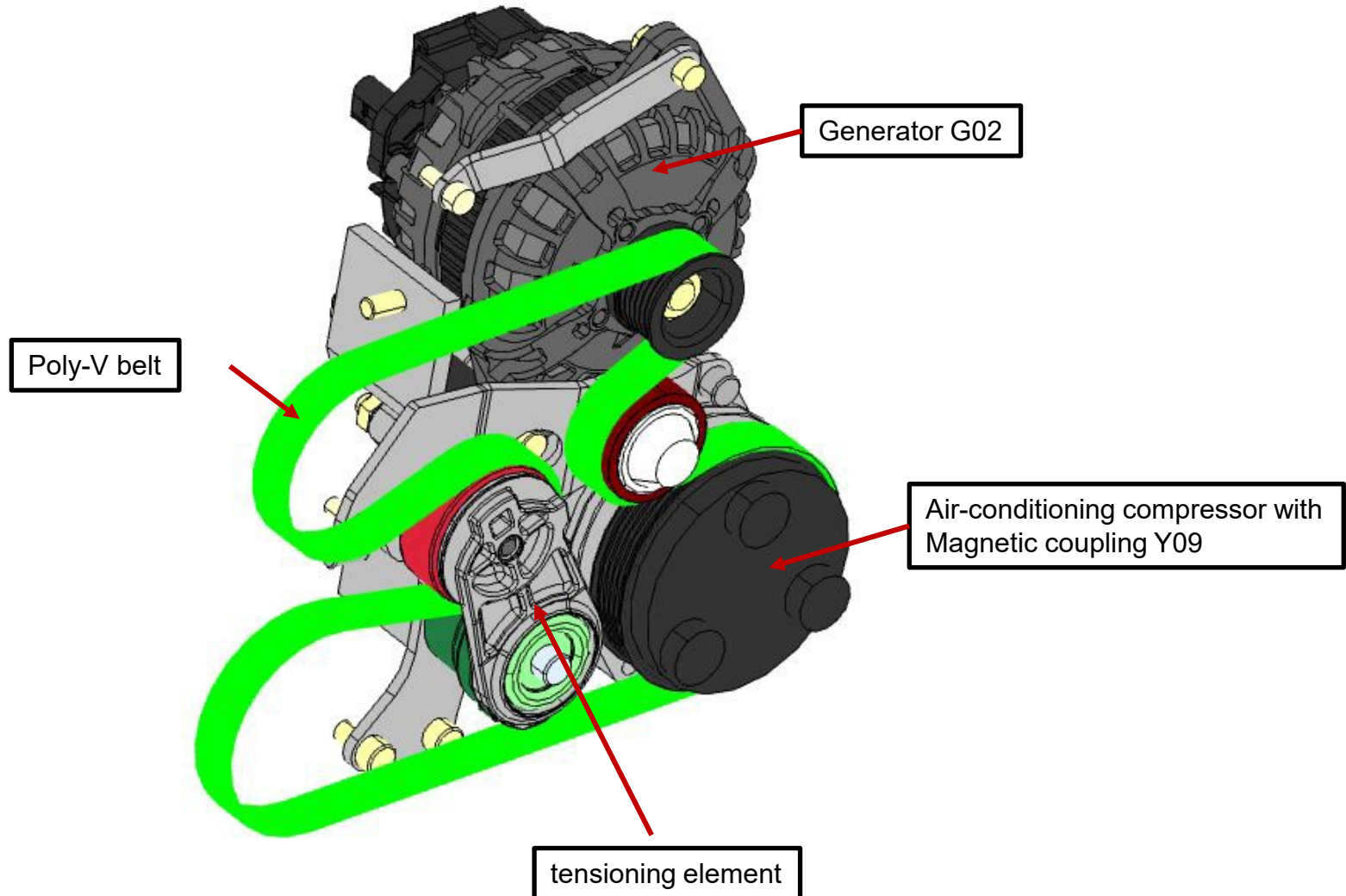

Fuel high pressure system

Overview

Rail-System

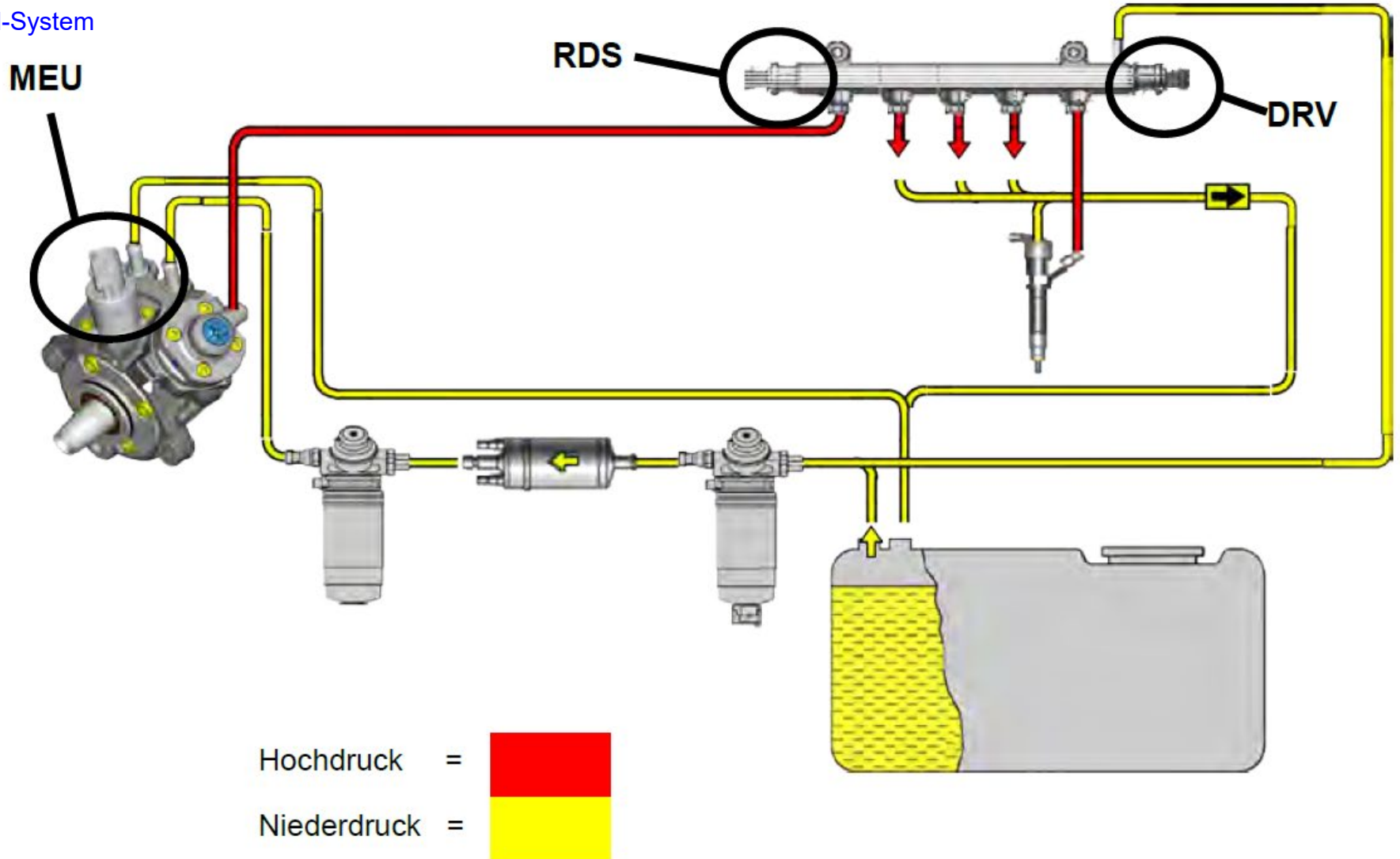

Fuel high pressure system

overview

Rail-System

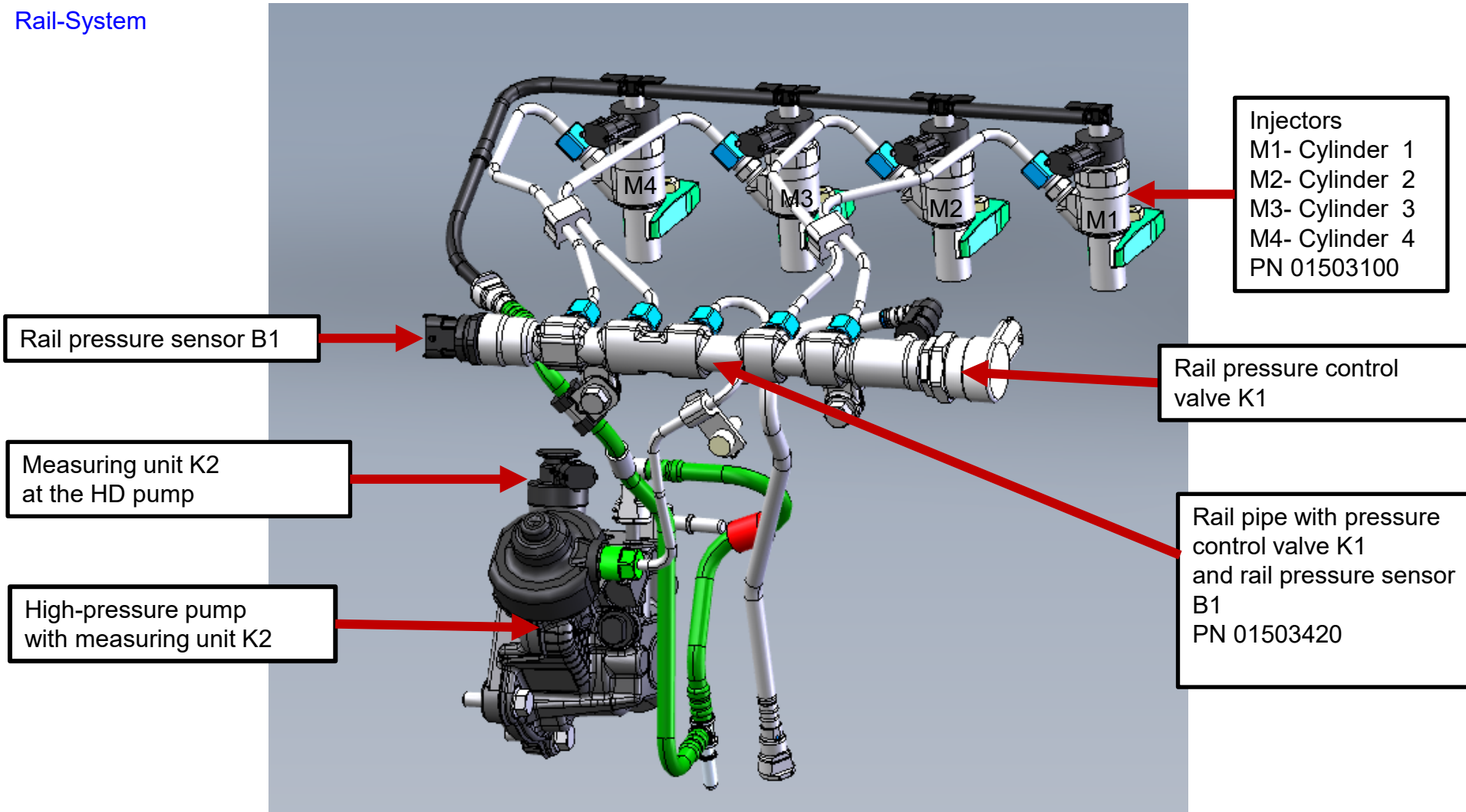



Fuel high pressure system

Function

1.Start

- The rail pressure is controlled via the DRV, and the MEU is switched to full delivery. (currentless or duty cycle 0).
- Due to the controlled fuel in the rail via the DRV, the fuel in the fuel system (lines, filter, but without tank contents) is heated.
- The rail pressure is controlled via the DRV until the start ejection.

2.End of start

- After starting, the "rail pressure control" is carried out up to a fuel temperature of approx. 30°C via the DRV at full delivery of the high-pressure pump (MEU).
- The actual rail pressure value (by the RDS) is compared with the setpoint from the maps and adjusted to a small deviation.

3.Engine running

- When the fuel temperature (measured at the filter by FLPS1) exceeds 30°C, the DRV is closed and the rail pressure is controlled via the MEU.
- The heating of the fuel is switched off from this moment on. The setting of the desired rail pressure (setpoint) is specified via various maps in the control unit and from this point is controlled by the metering unit (MEU).
- If the fuel temperature drops below 20°C during operation, the DRV is opened again and warms up the fuel in the prefilter.

Fuel high pressure system

Injector

The injector is controlled via the "Injector output" connections. This output is divided into "high side" and "low side". These actuators have no permanent ground or B+ connection. They are switched individually and on both sides by the control unit. Switching cycles for several injections are stored in the control unit software. Because the solenoid valve in the actuator must react quickly (microseconds), the current is higher during the switch-on process. The function test of the injector can be measured via a resistance value of 0.3-0.5 ohms at 20°C. A 100% statement cannot be made in this range. In the injection strategy of the 3/4H50TIC, the maximum number of injections per working stroke is limited to 2. Depending on the load and speed, it is varied between either pre-injection and main injection, main injection only or main and attached post-injection. The main purpose of pre-injection is to reduce noise in the lower speed and load range, while the main purpose of post-injection is to reduce particulate emissions in the upper speed and power range.

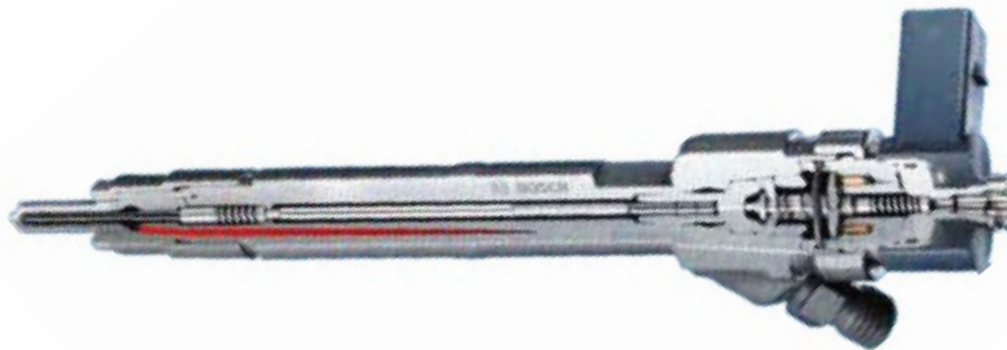

Fuel high pressure system

Injector

IMA code:

The IMA code (injector quantity adjustment code = alpha-numeric code) has the task of individually correcting the injection quantity for each injector of a CR system in the entire characteristic map range. To reach the setpoint, the difference to the actual injection quantity value is increased or reduced via the EDC adjustment values. This is corrected via the control time (opening time) of the injector. In total, the 5 EDC adjustment values are determined at idle, partial load, full load, 1st pre-injection and 2nd pre-injection. Due to the large number of possible combinations, class formation for the injectors is impossible.

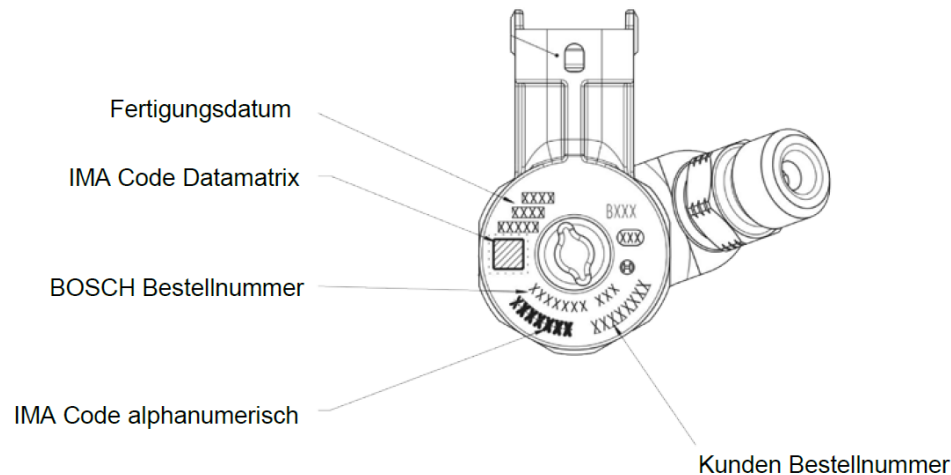

Engine-elektrics

Oveview

A01/K 94- poliger Stecker Motorsteuergerät 94- pole plug Engine Control Unit	A01/A 60- poliger Stecker Motorsteuergerät 60- pole plug Engine Control Unit
--	--

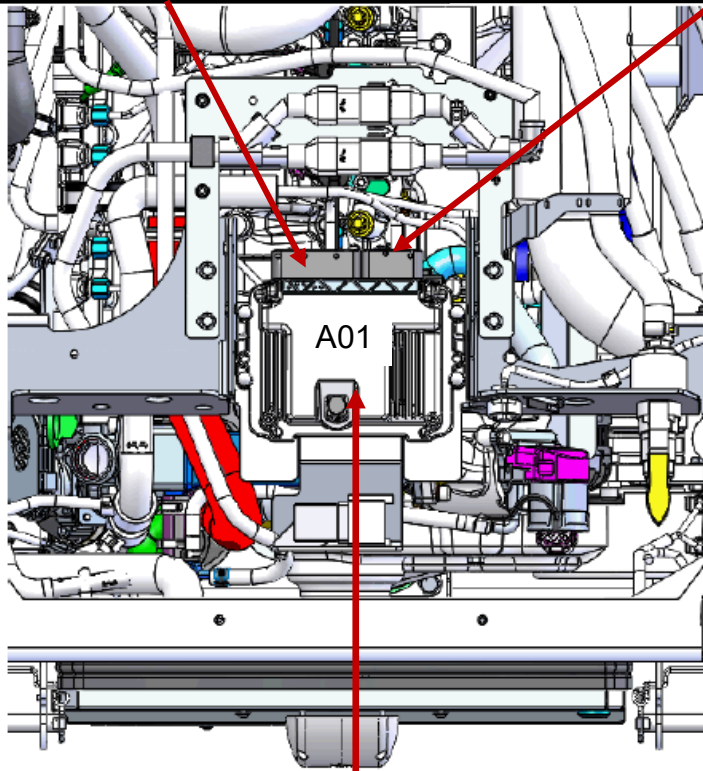

A100 Steuergerät- Glühzeitkontrolle
A100 CU- Pre Glow

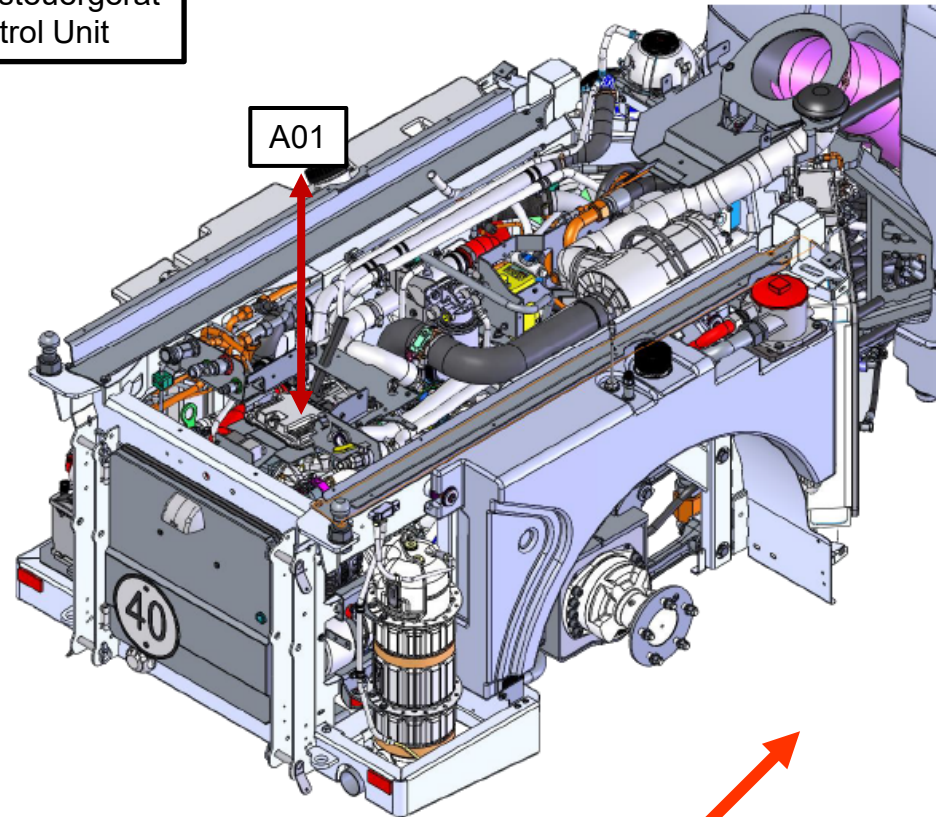

Fahrtrichtung - Driving Direction

Engine-elektrics

Overview of fuses

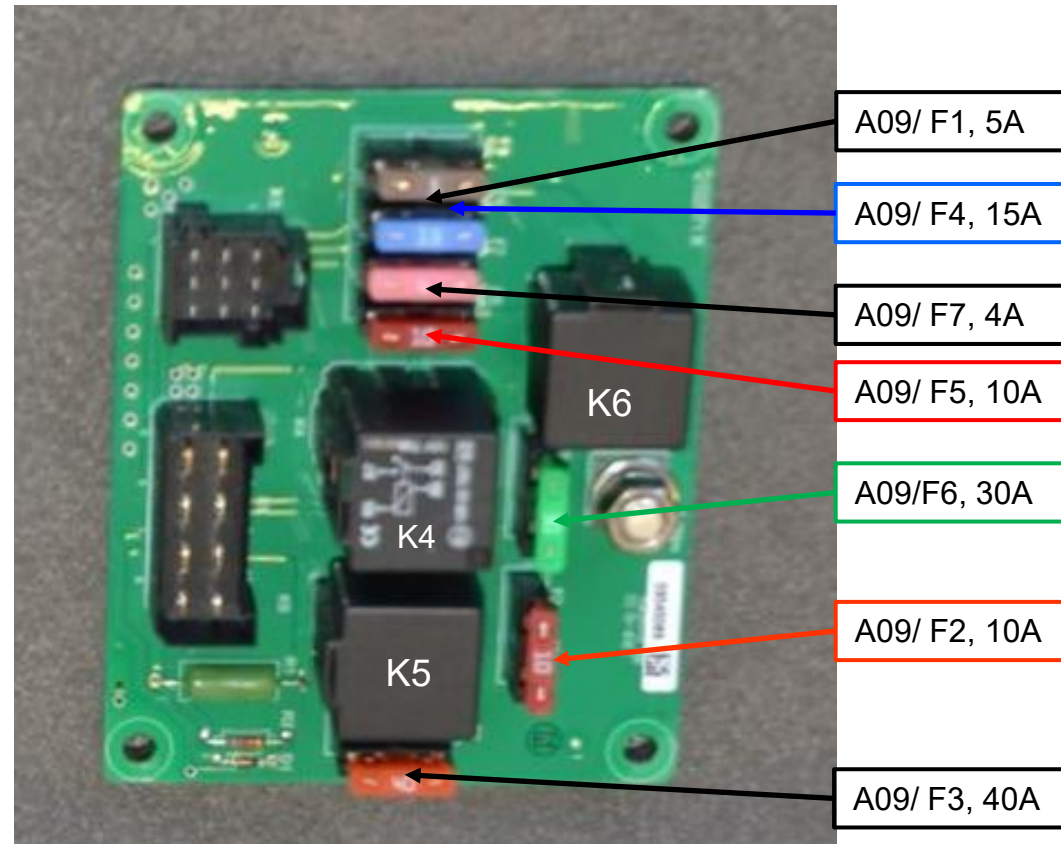
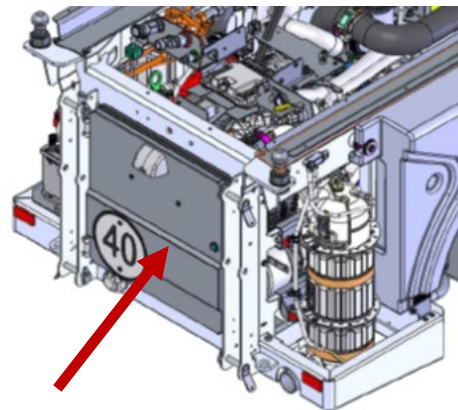
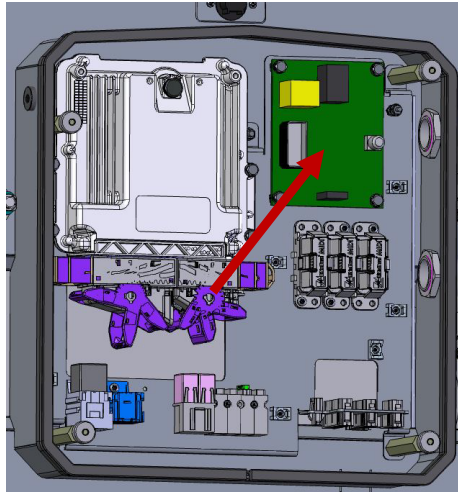

Engine-elektrics

Overview of fuses

Overview of the motor fuses on the motor board A09

F1 = Power supply Hatz diagnostic connector X59, **5A**

F2 = Power supply fuel pump M10, **10A**

F3 = Main fuse glow time control unit A100, **40A**

F4 = Power supply motor control unit A01, **15A**

F5 = Power supply water in fuel sensor B33, **10A**

F6 = Fuse magnetic switch starter M01, **30A**

F7 = Release glow time control unit A100, **4A**

DPF Regeneration

principles

Passive regeneration:

Soot reduction as a natural chemical reaction in a temperature range of 250-450 °C. No active control via engine control unit.

Active regeneration:

Soot reduction that takes place as a thermal reaction in a temperature range of > 550 ° C. This temperature range is only achieved through active engine management.

Dynamic regeneration:

Active regeneration (see above) during normal machine operation.

Advantage: No wasted power, no downtime.

Standby regeneration:

Active regeneration during machine downtime. The engine runs in a fully automatic cycle at a pre-programmed high idle speed.

DPF Regeneration

Grundsätze

250-450°C: Umwandlung von C + 2 NO₂ zu CO₂ + 2 NO
 >550°C: Oxidation von C + O₂ zu CO₂ + Energie

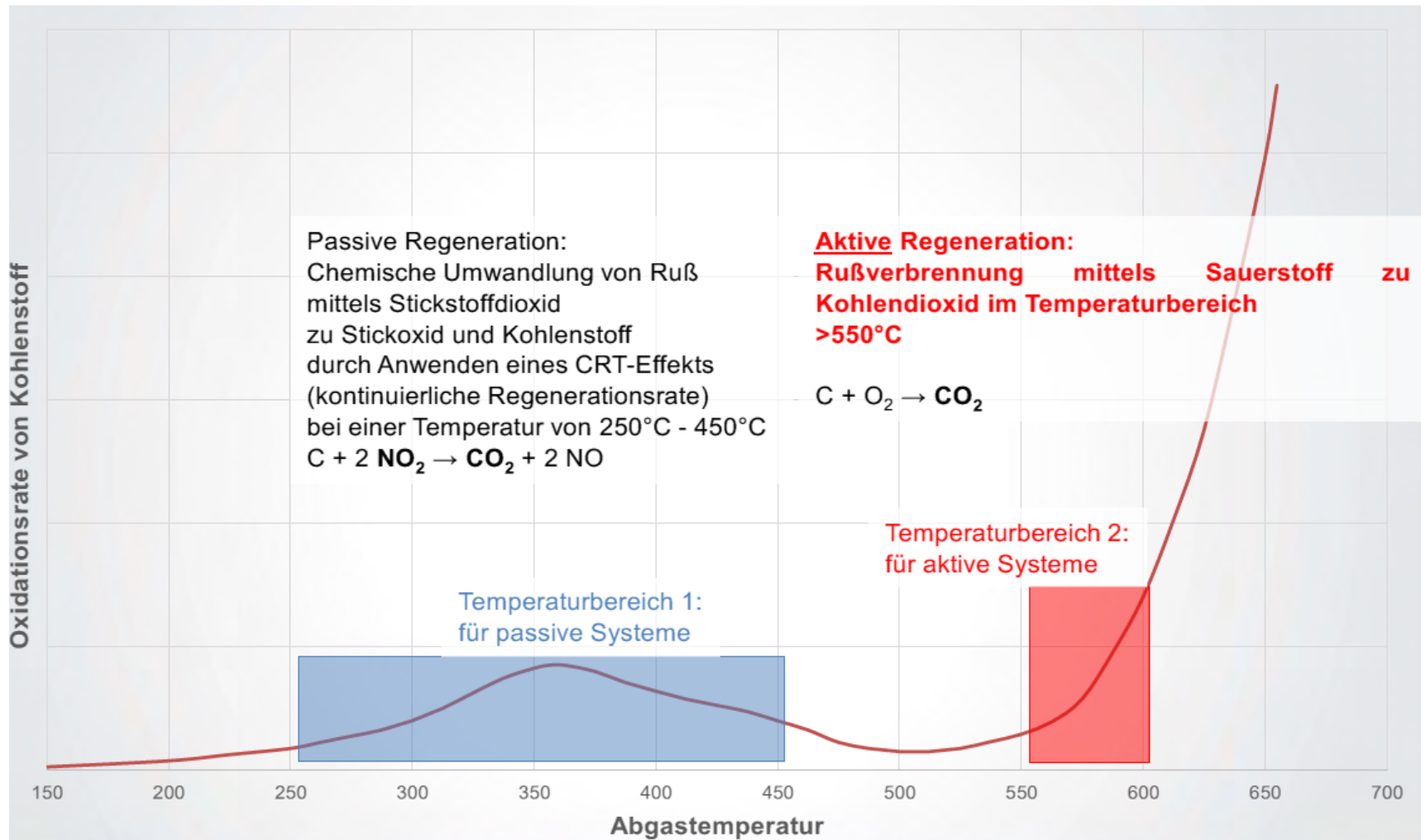

DPF Regeneration principles

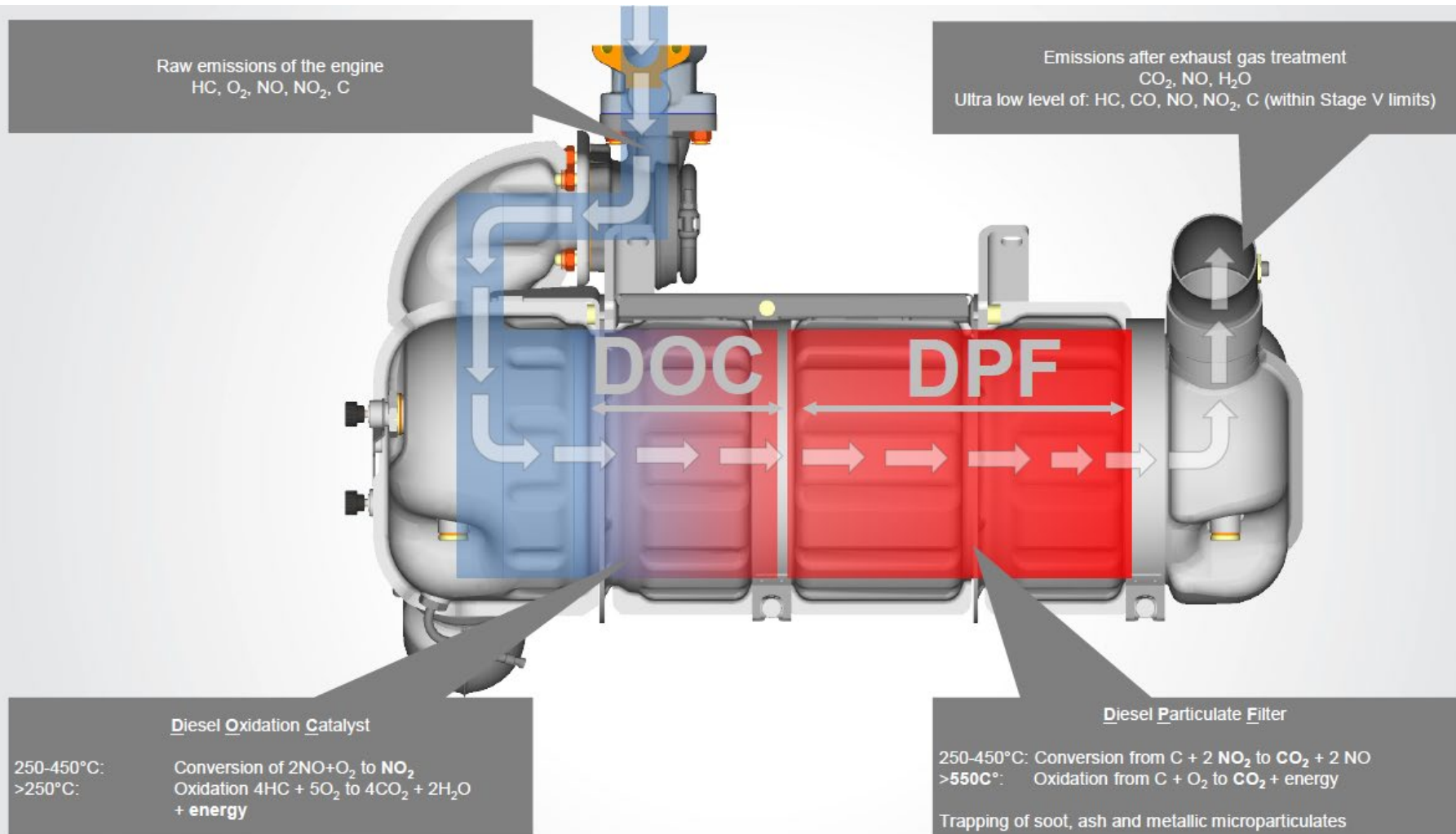

DPF Regeneration principles

90% 25,2g
7,7 g/l



100% 28g
8,5 g/l 60h



124% 35g
10,5 g/l 78h



Aktivierung bei 136%
38g 11,5 g/l
Heilung bei
35g 10,5 g/l



- Regeneration not necessary
- Start stand regeneration possible from 90% 25.2g 7.7 g/l
- up to 136% 38g 11,5 g/l
- Regeneration necessary during engine operation
- Activation either via automatic release conditions or request switch by the operator
- Prohibition switch must be deactivated
- Last possibility Stand regeneration by operator
- Necessity of stationary regeneration when the vehicle is at a standstill with low load
- Activation via demand switch by the operator
- Deactivation of the prohibition switch
- Neutral gear active
- Handbrake active
- Emergency stop or engine shutdown activated via fault path DFC_PFltSotMsMax due to possible damage to the particle filter
- Regeneration request only possible via diagnostic tool



DPF Regeneration

principles

Dynamic regeneration takes place while the machine is running. This requires the engine to run for at least 30 minutes. Furthermore, the engine must be operated within a certain load range. The CM1650 is designed so that this load range is always exceeded during operation.

A standby regeneration must be actively triggered. For this purpose, the engine must be running, but the machine must not be in use. The process is "triggered" and then starts automatically.

A standby regeneration is requested by the engine control unit if one of the following conditions is met:

- **Differential pressure sensor reaches the limit value (corresponds to 28g)**
- **Calculation model reaches 100% load**
- **Every 60 hours**

DPF Regeneration process

- **Temperature before DOC < 280°C beginning with preconditioning for regeneration.**
 - Preconditioning actions:**
 - **Regeneration active on (from ECU SPN3700=1)**
 - **EGR closed**
 - **Injection strategy uses later injection timing**
 - **Air throttle valve control**
- **If temp. before DOC doesn't exceed 280°C within 25 minutes (dynamic) or 15 minutes (standby), break for 120 minutes to avoid massive oil dilution.**
- **Temperature before DOC >280°C starting regeneration process**
 - **Regeneration active on (from ECU SPN3700=1)**
 - **no preconditioning actions needed, directly go to next step of regeneration**

DPF Regeneration

process

After preconditioning is done (temp. before DOC exceeded 280°C) the actual soot reduction process starts:

- Regeneration actions:
 - Regeneration active on (from ECU SPN3700=1)
 - EGR closed
 - Injection strategy uses later injection timing
 - Air throttle valve control
- } Same actions than preconditioning !
- Fuel injection near lower piston position. This fuel doesn't burn in cylinder but is only transported to DOC and is reacting with the coating there for heating up DOC/DPF to 550-650°C.
 - Cylinder shut-off (2-cylinder mode, standby only)
 - speed increase to preset regeneration speed (standby only)
 - High temperature message on (from ECU SPN3698=x1x)
- At these temperatures the soot within the DPF gets burned till process counter reaches 100%
 - When process counter reaches 100%:
 - EGR control active again
 - Injection strategy back to standard
 - Air throttle fully open again
 - High temperature message off (from ECU SPN3698=x0x)
 - Regeneration needed off (from ECU SPN3701=0)
 - Regeneration active off (from ECU SPN3700=0)



DPF Regeneration

Interruptions

I. Engine stop:

5 minutes interruption after restart!

II. activate prohibition switch (On):

No regeneration until the prohibition switch is switched off again.

III. After prohibition switch "Off" and 5 minutes pause:

Temperature before DOC > 280°C Continue regeneration

Temperature before DOC < 280°C Start of basic conditions for regeneration

IV. Required exhaust gas temperature cannot be maintained due to permanent load deficiency:

120 min pause before starting dynamic regeneration. Standby regeneration immediately possible.

V. Standby regeneration:

Exceeding the torque limit of 60Nm / parking brake "Off"/ neutral gear "Off".

5 minutes pause for dynamic regeneration, standby regeneration immediately possible

VI. engine starts load reduction:

Regeneration request ignored and soot load of 124% reached! Service regeneration is required!